

## VIDEO LIGHTS & PHOTOFLOODS

These lamps are used for constant source lighting for photography and videography.

HMI and high output studio lamps are available but are not listed here. Please call for more information.



FIGURE 5.



FIGURE 6.

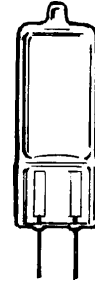

FIGURE 7.

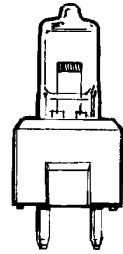

FIGURE 8.

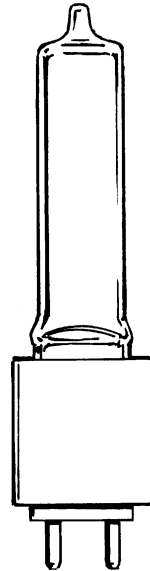

FIGURE 9.

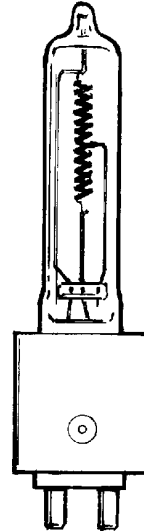

FIGURE 10.



FIGURE 11.



FIGURE 1.

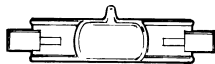

FIGURE 2.

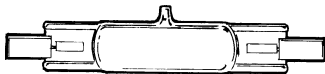

FIGURE 3.

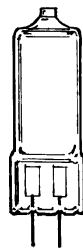

FIGURE 4.

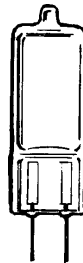

FIGURE 12.



FIGURE 14.



**bulbman**

**1-800-648-1163**

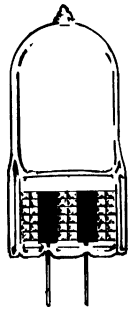

FIGURE 15.



FIGURE 16.

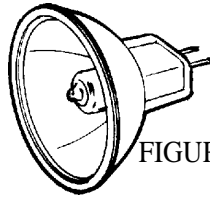

FIGURE 17.

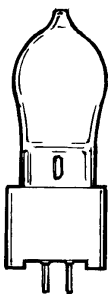

FIGURE 18.

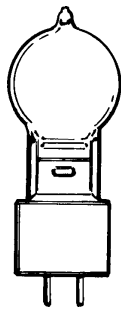

FIGURE 19.

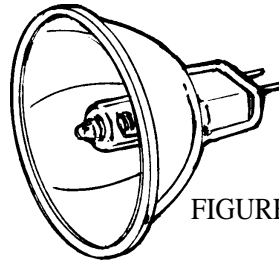

FIGURE 20.

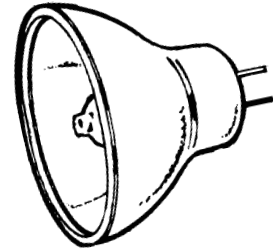

FIGURE 21.

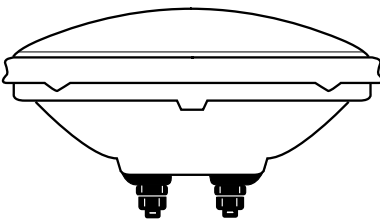

FIGURE 22.

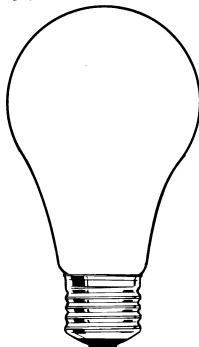

FIGURE 23.

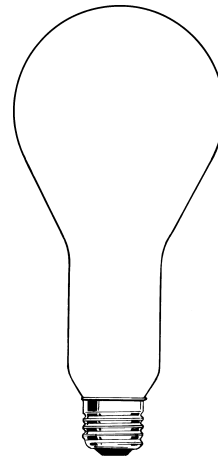

FIGURE 24.

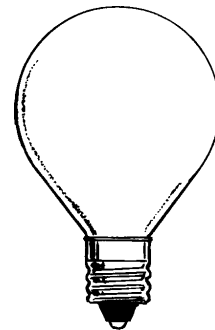

FIGURE 25.

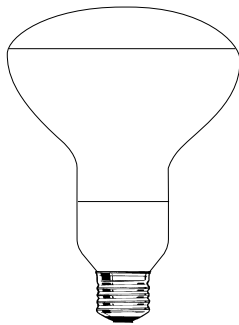

FIGURE 26.

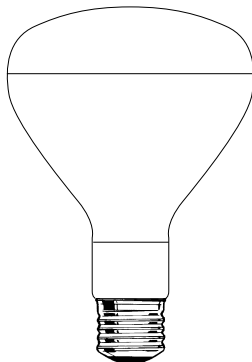
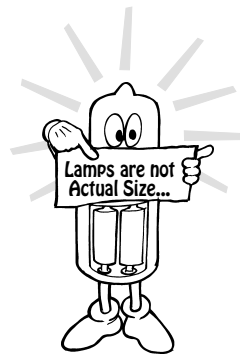

FIGURE 27.



bulbman

1-800-648-1163

# VIDEO LIGHTS

## (\* NOTE:

Bulbs with an asterisk (\*) are available with one or more of the following variations:

**CC = Constant Color**  
Constant white light with no beam discoloration and no loss in light over the lamp life.

**GL = Glass Lens**  
Cover glass lens protects bulb from dust and dirt which can reduce light output.

**DC = BA15D Base**  
(dual contact)

**GL/UV = Glass Lens and Ultra Violet Coating**  
Ultra violet filter glass lens blocks out UV, you get less fading and discoloration of objects being lit such as artwork and clothing.

**Black = Black Coating on Back of Reflector**  
Heat and light emit forward, rather than through the back of the lens.

**D = Daylight**  
Has daylight color of 5200° Kelvin, used for color matching.

**Ultra = Longer Life**  
10,000 hours or twice the life of an MR16.

**Silver = Silver Coating on Back of Reflector**  
Heat and light emit forward, rather than through the back of the lens.

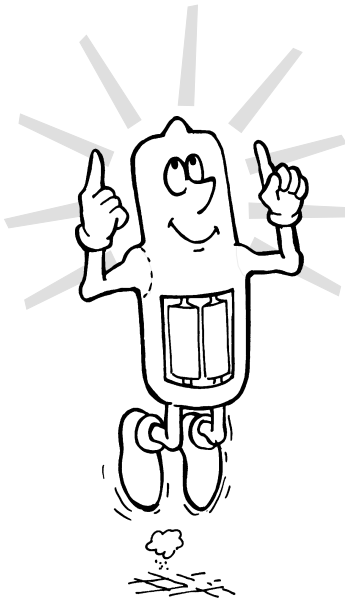

SINCE 1975

PART#	VOLTS	WATTS	BASE	SHAPE	LIFE	Kelvin	FIG#
BAB*	12	20	GX5.3	MR16	3000	3000	20
BRL	12	50	G6.35	T3.5	50	3400	4
DRA	120	300	G6.35	T4	300	3100	7
DWY	120	650	R7S	T4	25	3400	2
DXW	120	1000	R7S	T5	150	3200	3
DYB	120	1000	R7S	T3	15	3400	1
DYC	245	1000	R7S	T4	15	3400	2
DYG	30	250	GY9.5	G6	15	3400	19
DYH	120	600	G5.3	G7	75	3200	18
DYS	120	600	GY9.5	G7	75	3200	19
DYS-5	126	600	GZ9.5	G7	150	3200	19
DZB	12	100	G5.3	T3	50	3300	16
EGW	120	650	GX6.35	T7	15	3400	15
EGY	225	1000	GX6.35	T7	15	3400	15
EHC	120	500	G9.5	T4	300	3200	10
EHD	120	500	G9.5	T4	2000	3000	10
EHF	120	750	G9.5	T6	500	3200	9
EHG	120	750	G9.5	T6	2000	3000	9
EHJ	24	250	G6.35	T4	50	3400	7
EHJ-FR	24	250	G6.35	T4	50	3400	7
EKB	120	420	GY9.5	G7	75	3200	19
EKD	120	650	GY9.5	G6	25	3300	18
ELJ	120	1050	R7S	T5	75	3200	3
EMD	120	750	R7S	T3	400	3200	1
ENH	120	250	GY5.3	MR16	175	3250	20
ENH-5	125	250	GY5.3	MR16	225	3250	20
EPN	12	35	GX5.3	MR16	50	3300	20
ESA	6	10	G4	T3	100	3200	5
ESB	6	20	G4	T3	100	3200	5
ESX*	12	20	GX5.3	MR16	3000	3000	20
ESX/13.8V	13.8	25	GX5.3	MR16	500	3150	20
ESY	100	150	G6.35	T4	200	3075	7
EVD	36	400	GY6.35	T6	50	3200	14
EXM	6.82	45	GZ9.5	T3.5	1000	2950	8
EXN*	12	50	GX5.3	MR16	3000	3000	20
EXS	30	200	GX5.3	MR16	50	3300	20
EXT*	12	50	GX5.3	MR16	3000	3000	20
EXV	12	100	GX5.3	MR16	50	3350	20
EXX	120	250	GY5.3	MR16	25	3300	20
EXZ*	12	50	GX5.3	MR16	3000	3000	20
EYH	120	250	G5.3	G6	200	3050	18

bulbman

1-800-648-1163

# VIDEO LIGHTS

PART#	VOLTS	WATTS	BASE	SHAPE	LIFE	Kelvin	FIG#
EZK	120	150	GY5.3	MR16	200	3200	20
FAD	120	650	R7S	T4	100	3200	2
FBT	30	150	E10	T3.5	6	3400	6
FBV	30	250	E10	T3.5	6	3400	6
FBW	30	350	E10	T3	6	3400	6
FBX	120	650	R7S	T4	100	3200	2
FBY	120	1000	R7S	T5	150	3200	3
FCL	120	500	R7S	T3	2000	3000	1
FCL-130	130	500	R7S	T3	2000	3000	1
FCM	120	1000	R7S	T3	400	3200	1
FCM/HIR	120	650	R7S	T3	400	3275	1
FCR	12	100	GY6.35	T3.5	50	3300	12
FCZ	120	500	R7S	T3	2000	3000	1
FDF	120	500	R7S	T3	400	3200	1
FDN	120	500	R7S	T3	400	3200	1
FEL	120	1000	G9.5	T6	300	3200	9
FHM	120	1000	R7S	T3	400	3200	1
FPA*	12	65	GX5.3	MR16	3500	3000	20
FPB	12	65	GX5.3	MR16	3500	3000	20
FPC	12	65	GX5.3	MR16	3500	3000	20
FTB	12	20	GZ4	MR11	2000	2900	17
FTC	12	20	GZ4	MR11	2000	2900	17
FTD*	12	20	GZ4	MR11	2000	2900	17
FTE	12	35	GZ4	MR11	2000	2900	17
FTF	12	35	GZ4	MR11	2000	2900	17
FTH*	12	35	GZ4	MR11	2000	2900	17
GCA	120	250	G5.3	T3.5	200	3200	16
GCB	30	200	G5.3	T3.25	200	3200	16
GCC	12	100	G5.3	T3.5	200	3200	16
JC12-20W/G1	12	20	G6.35	T4	2000	2850	7
JC12-30W/G1	12	30	G6.35	T4	2000	2900	7
JC12-35W/G1	12	35	G6.35	T4	2000	2900	7
JC12-50W/G1	12	50	G6.35	T4	2000	3000	7
JCD120-100W/A	120	100	G6.35	T5.5	150	3000	11
JCD120-150CT	120	150	G6.35	T4	50	3200	7
JCR/M6-20W	6	20	GZ4	MR11	50	3200	21
JCR/M7.2-15W	7.2	15	GZ4	MR11	50	3200	21
JCR/M9.6-20W	9.6	20	GZ4	MR11	50	3200	21
JCR/M12-20W	12	20	GZ4	MR11	50	3200	17
JCR/M12-30W	12	30	GZ4	MR11	50	3200	21

## NOTE:

**Bulbman also supplies lamps for the following applications:**

- Automotive
- Commercial
- Dental
- Entertainment Lighting
- Graphic Arts
- Industrial
- Medical
- Micrographics
- Optical
- Residential
- Scientific
- Stage
- Studio

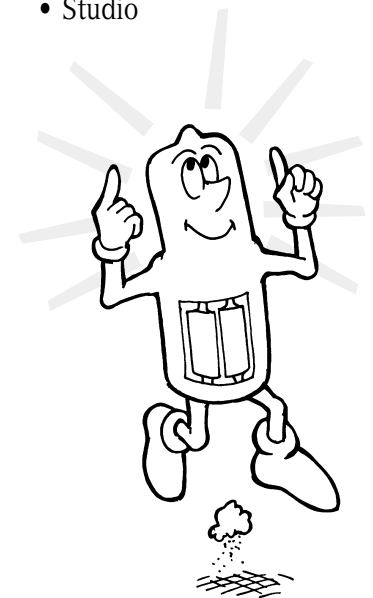

**bulbman**

**1-800-648-1163**

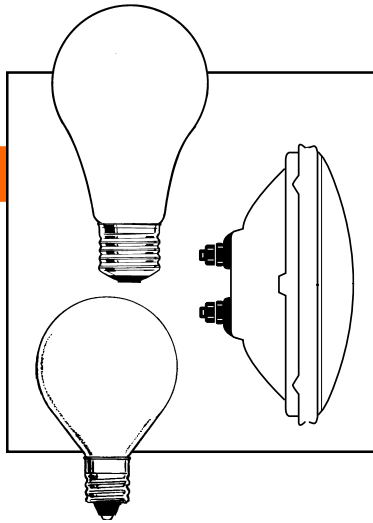

# PHOTOFLOODS

Photofloods are designed to operate at a specific Kelvin temperature. The rated life of these lamps are usually low, some rated at only three hours.

TYPE	Volts	Watts	Base	Shape	Life	Kelvin	Fig#
BAH	115	300	E26	A21	20	3200	23
BBA	115-120	250	E26	A21	3	3400	23
BCA	120	250	E26	A21	3	4800	23
BEP	115-120	300	E26	R30	4	3400	26
BLK	120-130	30	E12	S11	50	2700	25
DXB	115-20	500	E26	R40	6	3300	27
DXC	120	500	E26	R40	6	3300	27
EAL	120	500	E26	R40	15	3200	27
EBV	115-120	500	E26	PS25	6	3400	24
EBW	115	500	E26	PS25	6	4800	24
ECA	120	250	E26	A23	6	3200	24
ECT	120	500	E26	PS25	60	3200	24
FGS	120	250	FERRULE	PAR36	4	3400	22

## WHAT CUSTOMERS ARE SAYING ABOUT BULBMAN

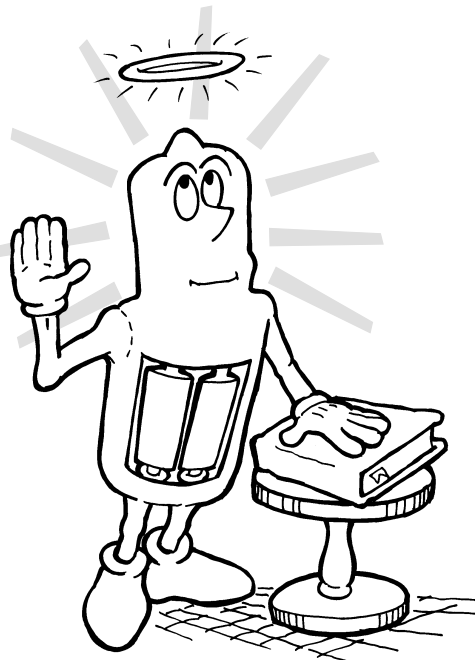

“Great Stock, Very Helpful Sales Staff, Quick Delivery, Excellent Customer Service Backup, Our #1 Distributor Supplier.”

Yehuda Goldstein,  
B&H Photo-Video  
New York, NY

“Doing business with Bulbman is like having their stock in our store. Quick delivery enables us to promise any lamp very quickly. Ordering from the Major Manufacturers was always a problem. That problem has been eliminated by Bulbman.”

Ron LoPinto,  
Arista Camera  
Bronxville, NY



**bulbman**

**1-800-648-1163**

## WHAT OUR CUSTOMERS SAY...



“We purchase from over 100 suppliers and rank Bulbman #1. You have the best people, customer service, price and delivery. We no longer buy direct from Sylvania. Thank you Bulbman.”

Don Kimberly,  
Photo Reproduction Materials  
Walled Lake, MI

“Bulbman is a retailer's best friend. As an independent camera supply store, it's great for our customers to know that virtually any bulb is just 1-2 days away with Bulbman. We keep minimal stock of the more popular lamps and let Bulbman do the rest!”

Keith Kodkinson,  
Great Lakes Photo  
Tiffin, OH

“You have always had the shining example of the best customer service! Not only that, but you have the best inventory and price, why go anywhere else!”

Stockley Wilson,  
King Photo Supply  
Lancaster, CA

“Bulbman never disappoints. They have the product and get it to us quick. The people are always friendly and knowledgeable. First class all the way.”

Phil Watkins,  
Photo Den  
Grants Pass, OR

“We look for three things in selecting a supplier:

- 1) Efficiency
- 2) Competitive Pricing
- 3) Courtesy, warmth and a desire to please

On a scale of 1 - 10, we give Bulbman an 11 on each criterion. If only all our suppliers were trained by Bulbman.”

Lou Nicholas,  
Chula Vista Photo  
Chula Vista, CA

“Thanks for 10 years of continued great service!”

Wilson Parish,  
Alamo Photo Labs  
San Antonio, TX

“Best selection of lamps in the U.S.! Always willing to accommodate rush orders. Always willing to help in cross reference on odd lamps. You're great.”

Tom Burch,  
Henleys Photo, Inc.  
Bakersfield, CA

“Prices are very competitive and in some cases quite a bit lower than other wholesalers. Personnel is very knowledgeable of products and friendly. Service – None better. Orders are completed and delivered promptly and accurately. Thank you for not having an automated telephone system.”

Bill McDuffy,  
Camera Center  
San Rafael, CA



# bulbman

# 1-800-648-1163